

# USER GUIDE



## ANGRY AUDIO

**PHONE**

+1 (615) 763-3033

**WEB**

answers@angryaudio.com  
www.angryaudio.com

**ADDRESS**

128 HOLIDAY CT STE 118  
Franklin TN 37067 USA



## Chameleon C4 Livestream Audio Processor

P/N 991036

Revision 2.0  
02/2024

## Welcome to the world of Angry Audio, home of Audio Chameleon.

Since the beginning of time, man has sought to control the sounds of his environment. Cave-dwellers needed to eliminate echo, hunter/gatherers wanted low-pass filters for mastodons, and early settlers of Peru's high mountains had a deep desire for effective peak control (get it?).

Seriously though – engineers from the dawn of broadcasting have sought to tame the dynamics of their content with ever-improving technology. The first analog limiting amplifiers gave way to multi-band processing, which in turn was supplanted by DSP. But getting the basics right and sweating the details – those things will never be obsolete.

A good studio is built by including components that make it a convenient and enjoyable place to create the content that dazzles your listeners, drives traffic to your advertisers, and lets you keep the summer place in Jackson Hole.

Accordingly, every Angry Audio product – including this Chameleon audio processor – is designed to solve common yet critical problems, and is meticulously engineered with performance and longevity in mind to deliver pristine audio and reliable performance for many years.

## Our promise and guarantee.

Folks who install Angry Audio products generally think they're the bee's knees, and we hope you'll feel the same. That's why we give you 30 days to laugh, cry, and hug it out with your Chameleon audio processor. If you find you lack the emotional attachment you were hoping for, we'll buy it back.

Every Angry Audio product is warranted to be free from defects in parts and workmanship for two full years after you purchase it. If it fails within this time period, Angry Audio, at its discretion, will repair or replace it so long as you let us know of the failure within the warranty period and can provide proof of purchase in the form of a dated sales receipt. You can call us at +1 615-763-3033, or reach us online at [www.angryaudio.com/contact](http://www.angryaudio.com/contact).

## Making a good first impression.

When you unbox your Chameleon audio processor, we hope it makes a good first impression and you take a moment to appreciate the lengths we've gone to in order to create a "built for broadcast" product. All of our products are over-engineered to provide long-term reliability and guaranteed RFI immunity. Some of this is apparent – such as the durable powder-coated steel enclosure – but much of this goodness is invisible, like the premium components within. Even if you can't see it, you'll hear it!

## A word or two about safety.

The fact that you've purchased an Angry Audio product proves without doubt that you're an intelligent person – not the sort who would intentionally fire up a kerosene heater in the house, or drop a frozen turkey into a vat of boiling oil. Nevertheless, our legal eagles tell us we must provide some boilerplate in order to guard against the unexpected.

Audio gadgets aren't nuclear generating stations or air traffic control consoles, but they are still intended for use by qualified personnel. To avoid electric shock, do not open the unit or attempt to perform any servicing unless you are qualified to do so.

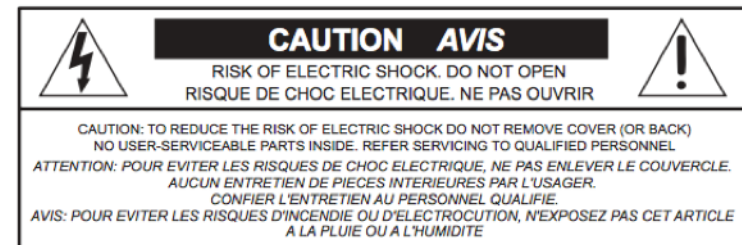

Chameleon audio processors have an internal 120VAC / 240VAC power supply. Hazardous voltages are present whenever the unit is plugged in and may still be present on certain components even when the unit is unplugged.

The power cord is the primary disconnect device and so the outlet providing power to the unit should be easily accessible. In other words, make sure you can pull the plug in case of emergency. Use only a properly grounded outlet for power. Do not cut the ground pin or use a ground-lifting adapter, and do not defeat the polarized plug. Do not overload outlets.

Do not expose your Chameleon to rain or moisture. Do not block any ventilation openings, as lack of airflow could damage the unit or create a fire hazard. Any electronic device can fail without warning; do not use this product in applications where a life threatening condition could result due to failure.

**Exercise caution with headphone volume. Permanent hearing damage may result from excessive volume.**

Never operate your Chameleon audio processor while driving; a car is a dangerous weapon. Do not attempt to feed raccoons by hand unless you think the nickname "Stumpy" will buff your status within your social circle. And for heaven's sake, throw out those powder-blue Sansabelt slacks you got in 1979. You're never going to get down or boogie-oogie-oogie in those again.

## Mounting your Chameleon in a rack.

Your Chameleon audio processor sits on four rubber feet that ensure it won't slide off the edge of your Lucite desk when your yacht heels over too hard.

If you prefer to rack mount your Chameleon, you'll need the optional Rack Mount Kit which allows one or two units to be installed side by side in a standard 1RU rack space.

Each Rack Mount Kit consists of a custom rack panel with cutouts for all front panel controls and displays. A blank filler panel is also provided if you are mounting only one unit.

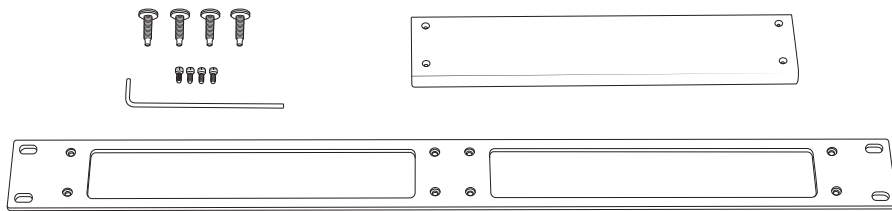

When rack mounting, remove the four rubber feet ("A") from the bottom of the gadget with a #1 Phillips screwdriver.

Remove the four front panel 3/32" hex screws ("B"). You can rummage around your toolbox for your own hex key, or use the one we thoughtfully provide in the mounting kit.

Line up the Chameleon so that the holes exposed after removing the socket head screws line up with the mounting holes ("C") in the rack panel.

Attach the rack panel to the front of your unit with the same screws you just removed. If you dropped one and it immediately got lost in the shag carpet (as these things always do), don't panic - we've included spares in the kit.

Finally, use the provided rack screws (all four, please) to mount your Chameleon.

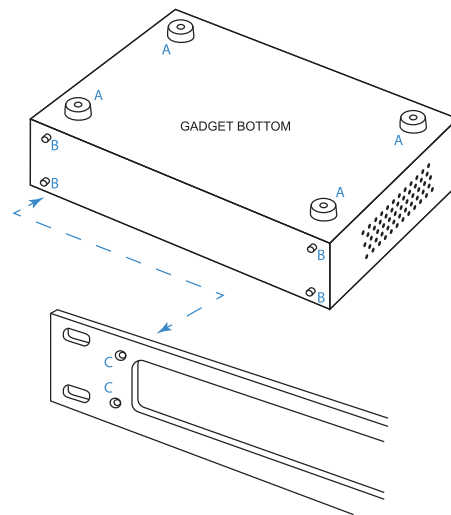

## Attaching your Chameleon to a wall.

We can't for the life of us image why you'd want to wall-mount an audio processor, but hey - you might. And if you prefer to secure your unit to the inside of a rack, cabinet, or other flat surface, the optional Wall Mount kit comes in handy.

Each Wall Mount Kit includes two brackets, four No. 6 screws, and four cup washers.

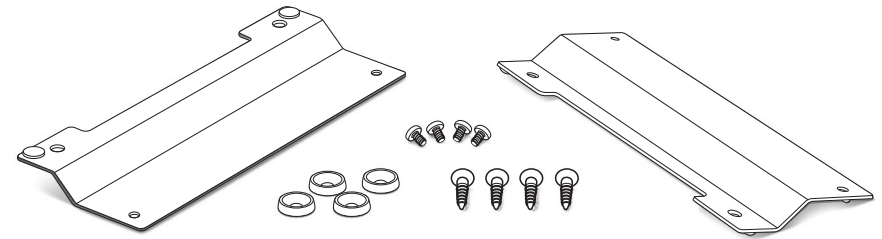

Remove the four rubber feet ("A") from the bottom of the gadget with a #1 Phillips screwdriver, being careful to save the screws.

Align the bracket holes with the holes in the bottom of the gadget, then attach the brackets using the screws removed from the rubber feet.

Use the four No. 6 screws ("B") and the four cup washers ("C") to secure the gadget to a plywood surface. Drilling pilot holes is recommended to reduce the risk of splitting the wood.

Different hardware (not supplied) will be required if you are mounting the gadget to a drywall (or other) surface.

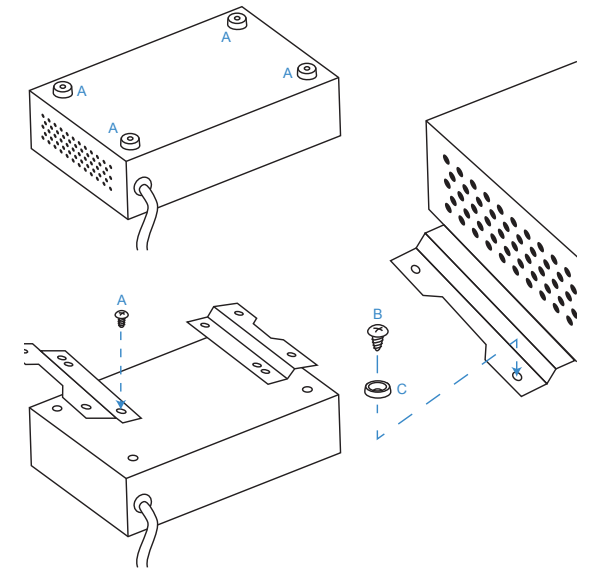

## Mounting your Chameleon under a counter.

Your Chameleon can be mounted under a counter, desk, or table using the optional Under Counter Mount Kit.

This kit includes two brackets, four No. 6 wood screws, and four cup washers suitable for mounting to a plywood surface. Different hardware (not supplied) may be needed if the mounting surface is a different material.

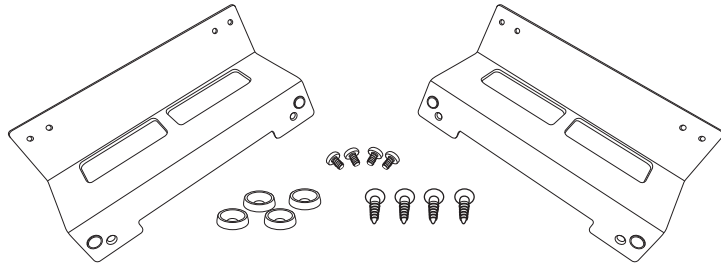

Remove the four rubber feet ("A") from the bottom of the unit using a #1 Phillips screwdriver, being careful to save the screws.

Line up the brackets ("C") so that their mounting holes line up with holes exposed after removing the rubber feet. Orient the brackets as shown in the diagram to the right so that the deeper flat side supports the gadget and the "notched" side faces the under-mount surface.

Use the pan-head screws ("B") removed from the rubber feet to secure the brackets to the gadget.

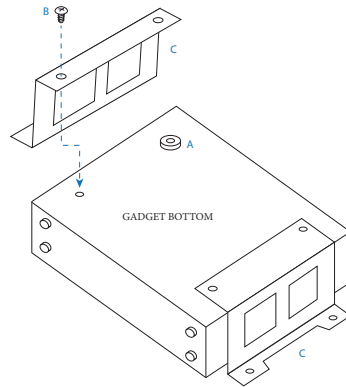

Use the four provided No. 6 screws ("D") and the four cup washers ("E") as shown in the diagram to the left to secure the gadget to the plywood underside of the counter, desk, or table.

Drilling pilot holes is recommended to reduce the risk of splitting the wood.

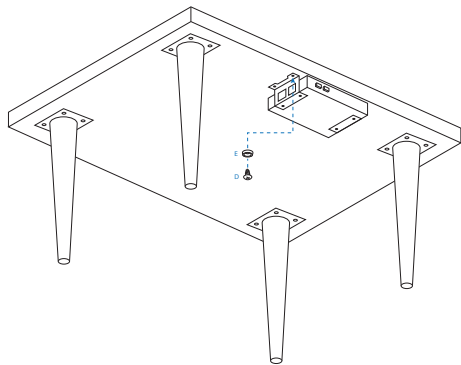

## Using your Chameleon on a desktop.

If you like the idea of using the Chameleon on a desktop but prefer a more permanent installation along with the convenience of having it angled up toward the user, we've got you covered with the optional Desktop Bracket Kit.

This kit includes two brackets, four No. 6 wood screws, and four cup washers suitable for mounting to a plywood surface. Different hardware (not supplied) may be needed if the mounting surface is a different material.

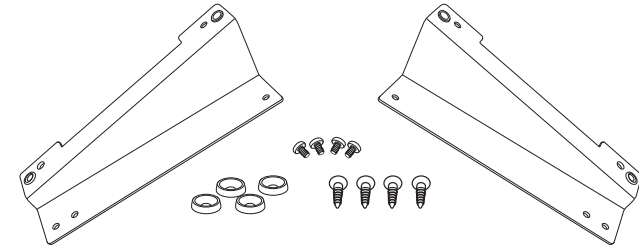

Remove the four rubber feet ("A") from the bottom of the unit using a #1 Phillips screwdriver, being careful to save the screws.

With the bottom of the Chameleon facing up and the front panel facing toward you, line up bracket "C" with the holes exposed after removing the feet on the right side of the gadget. Orient the bracket as shown in the diagram to the right so that the flat side is attached to the unit, and the "notched" side sticks up with the notch facing outwards. Use the pan-head screws ("B") removed from the rubber feet to secure the brackets to the unit.

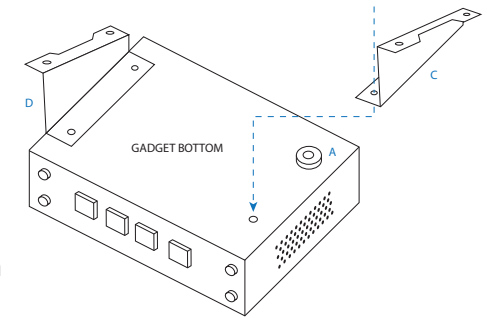

Use the four provided No. 6 screws ("E") and cup washers ("F") as shown in the diagram above to secure the gadget to a plywood surface.

Drilling pilot holes is recommended to reduce the risk of splitting the wood.

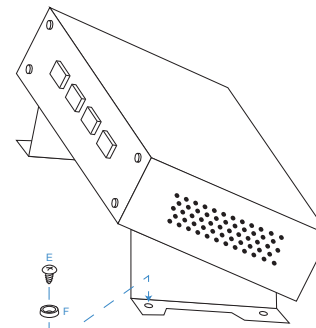

## Targeted loudness control for Livestreams.

You're familiar with the problem: you're listening to your stream and you notice that the loudness varies wildly. You've tried your best to make sure your meters stay as close as possible to 0dB, but for some reason you can't quite keep the perceived loudness from climbing and diving like a roller coaster at the county fair.

Broadcasters fix this problem with program audio processors that use a combination of signal modification tools to shape sound and control loudness. You've probably noticed how consistent broadcast audio usually is – all thanks to these (very expensive) devices filled with displays, meters, spectrographs and controls with labels like "Drive", "Overdrive" and "LightSpeed". You could spend years learning how to set up these devices – but who's got the patience? All you want is consistent sound!

Chameleon C4 gives you exactly what you're after. It employs an innovative, intelligent new approach to program audio processing. C4 analyzes the incoming audio and continually adjusts its parameters to fit the content. Rather than the usual bazillion knobs and buttons, C4 automates all that complexity. No need for the expert; just hook it up, flip a few switches, and Chameleon gets right to work.



To get that great "On the Air!" sound, Chameleon uses a form of A.I. (a benevolent form, not the evil Skynet kind) to continuously adjust its parameters to fit the content of your program audio. Chameleon has a very open and natural sound which preserves the character of your content whatever the format: rock, classical, country, pop, talk, commentary or sports.

C4 also features our exclusive precision loudness controller. When engaged, you can set any loudness target from -24LUFS to -14LUFS and your livestreams will be compliant with loudness standards from Apple, Youtube, AES (proposed), Amazon and others.

Easy to use? You bet. There are only 3 controls on the front panel; you'll be up and running in just minutes. Set your output loudness target, choose your level of processing, then sit back and start sending your subscribers to streaming Nirvana. Ahh...the sweet sound of success.

Dual-function LUFS/ level calibration control. Choose your loudness target; C4 does the rest.

Activity LEDs indicate processing, gating and clipping activity.

Volume control adjusts output level of both front-panel headphone jacks.

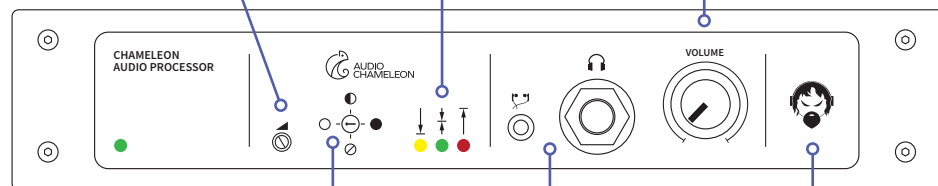

Density control. Choose from 3 processing density options, plus bypass.

1/4" and 3.5mm headphone jacks supported.

Don't make him angry. You wouldn't like him when he's angry.

Stereo analog inputs provided in both XLR and StudioHub+ format.

Stereo analog outputs on XLR connectors.

AES/EBU inputs and outputs on StudioHub+ connectors.

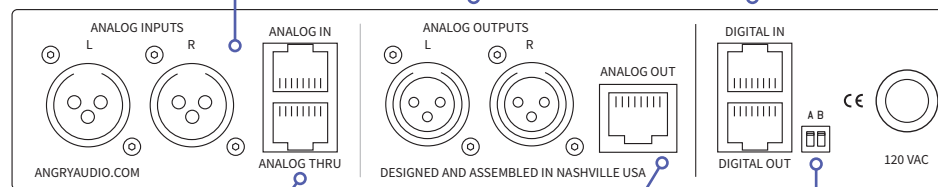

Analog pass-through on StudioHub+ connector lets you send input signal to other devices.

Analog output on StudioHub+ connector delivers audio + power to compatible devices.

DIP switches affect certain features and settings. Read further for details.



## Select your input source.

Chameleon C4 is equipped with both analog and digital audio inputs and outputs on XLR and StudioHub+ RJ-45 connectors.

### For units with Serial Number 300 and prior:

A DIP switch on the rear panel selects which input feed to use.

As shipped from the factory, analog is selected as the default input, but best performance will be achieved by using the digital input and output (AES/EBU) on StudioHub+ RJ45 connectors.

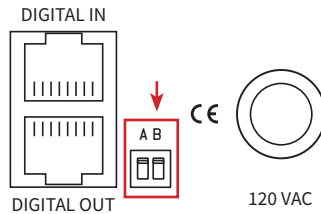

Find the DIP switches on the rear panel, adjacent to the line cord. For ANALOG input, leave DIP switch B in the “down” position. To select DIGITAL input, flip DIP switch B to the “up” position.

### For units with Serial Number 301 and higher:

DIP switch “B” controls the Detail Enhancer processing algorithm (see next page). Input source selection is now done automatically. Simply connect to your choice of inputs. If the AES and ANALOG connections are used simultaneously, the AES input will have priority and C-Level will use that audio. If the AES input falls silent for more than 20 seconds, C-Level will switch to the ANALOG inputs. This is useful for setting up automatic failover to a backup (analog) input.

## Feed other devices.

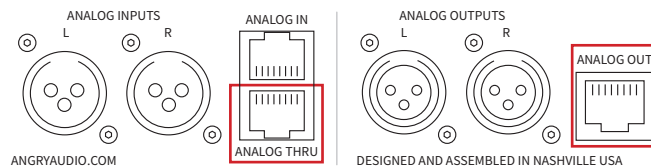

The Analog section of the rear panel hosts two items to take note of. The ANALOG THRU connector is useful for daisy chaining the same input source to multiple devices. The ANALOG OUT StudioHub+ RJ-45 connector provides audio and  $\pm 15\text{VDC}$  to certain types of connected devices.

## Processing controls.

Chameleon C4 is so easy to use that there’s hardly any tweaking to do. Put your Craftsman Heavy-Duty Titanium Tweak Tool back in the cabinet with the tape head demagnetizer to keep it from getting lonely. Choose your desired audio processing mode using the selector switch on the front panel:

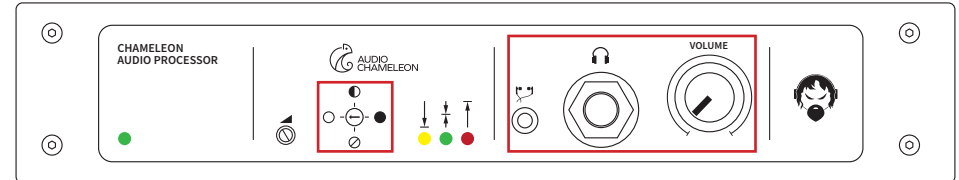

- The 6 o'clock position (⊙ symbol) is Bypass mode. This allows you to compare processed audio with unprocessed audio during setup.
- The 9 o'clock position (○ symbol) selects Open processing. This is the lightest processor setting; it delivers good dynamic range with a light amount of smoothing.
- The 12 o'clock position (● symbol) selects Medium processing. This gives a good amount of audio density, and is probably the setting most users will prefer.
- The 3 o'clock position (● symbol) selects Dense processing mode. It is the most processed setting, and delivers consistent loudness to the user.
- Volume knob at the far right of the front panel controls the volume of the two (¼" and 3.5mm) headphone jacks. These jacks are mutually exclusive.

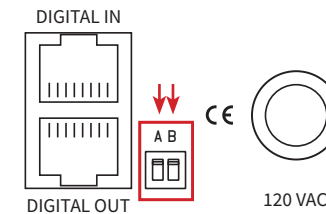

- Set DIP switch “B” on the back panel to the UP position to engage the Detail Enhancer, an algorithm that provides some enhancement and improved consistency on most materials - especially older music genres. Set DIP switch “B” to the DOWN position to bypass Detail Enhancer.

## Enable/Disable Loudness Controller.

To engage the BS.1770 loudness controller, set DIP switch “A” on the back panel to the UP position. To disengage, set switch to the DOWN position.

## Setting the Loudness Target.

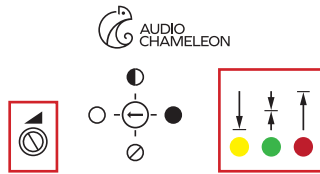

The Loudness Controller and the Calibration screw to the left of the front-panel processing selector work together to help you achieve your LUFs target.

- When Loudness Control mode is “off” (see Page 10), the Calibration control functions as an output level trim. In trim mode, C4 sets output level to -10 LUFs. In this setting, processing texture is more “dense”, comparable to broadcast radio. LUFs can be adjusted by using the Calibration control to reduce the output level without changing audio processing texture.

When Loudness Control mode is set to “on” (see Page 10), the front-panel Calibration screw becomes a multifunction control to adjust the LUFs target. This is a multi-turn screw without end-stops.

- When the Calibration control is turned 20 turns (or more) clockwise, Loudness Target is set to -14 LUFs.
- When the Calibration control is turned 20 turns (or more) counter-clockwise, Loudness Target is set to -24 LUFs. As LUFs target is reduced, so is audio density texture.
- To achieve LUFs settings inside the -14/-24 range, a LUFs meter is required. We recommend the free [Youlean Loudness Meter](#) software.

## The Activity Display.

The three LEDs found on the front panel tell you what’s going on inside Chameleon C4’s processing engine.

- The Amber LED at left is the “Gain Lock” indicator. This indicates that processing is frozen and that gating is active.
- The Green LED at center tells you that the processing section is engaged and audio is actively being processed.
- The Red LED at right tells you that your audio is overdriving the C4’s inputs and that clipping is occurring. Reduce input gain until the LED darkens.

## “What is LUFs and why should I care?”

Good question! LUFs stands for Loudness Units Full Scale. It’s a standardized way to measure the perceived loudness of audio content. Instead of just watching for the loudest bits of audio and squeezing them down, LUFs looks at the overall loudness of your content, providing a more accurate representation of how loud something sounds to listeners’ ears.

Audio engineers use LUFs to make sure that different songs or broadcast segments sound consistent, and avoids sending listeners scrambling for the volume button while shouting “AAAAAAHHHH!”

LUFs works no matter how you’re listening. Whether you’re streaming from your smartphone speakers, using high-quality headphones or listening in the car, LUFs control makes sure that the overall loudness will remain relatively consistent, avoiding random, startling volume changes.

LUFs also helps you, the streaming content originator, comply with your streaming platform’s loudness requirements.

For more about LUFs, loudness and levels, read Cornelius Gould’s white paper “[Audio Loudness in the Age of Digital Media](#)”, a free download from our site.

## LUFs targets for popular streaming sites

Nearly every streaming platform has a loudness standard for the content they deliver. If you deliver content compliant with that standard, your streams will sound great. If not, the streaming provider will normalize your content for you (insert ominous ‘*dun-dun-DUHHHH!*’ music here). It’s kind of like letting Grandpa salt your food: the result will NOT be what you wanted.

In short, the streaming platform only cares that its loudness target is met, not whether your content sounds good. So optimize your stream’s loudness levels to match the requirements of your service and you’ll be golden.

Here are loudness requirements from several common streaming platforms. If you use a different platform, ask your representative what their LUFs target is.

- Spotify: -14 LUFs
- Apple Music: -16 LUFs
- Amazon Music: -9 to -13 LUFs
- Youtube: -13 to -15 LUFs
- Deezer: -14 to -16 LUFs
- Soundcloud: -8 to -13 LUFs

## Specifications.

### Part Numbers

North America: p/n# 991036  
 Australia: p/n# 991036A  
 Europe: p/n# 991036E  
 United Kingdom: p/n# 991036U

Included in the box: Chameleon C4 Processing Gadget  
 Pocket trimpot adjustment tool

### Connections

Analog Input: Balanced +4dBu Stereo XLR connectors  
 Balanced +4dBu Stereo RJ45F connector  
 (StudioHub+ pinout)

Analog Through: Parallel to Analog Input (StudioHub+)

Analog Output: Balanced +4dBu Stereo XLRM connectors  
 Balanced +4dBu Stereo RJ45F connector  
 (StudioHub+ includes  $\pm 15\text{VDC}$ )

Digital Input: Transformer isolated, AES/EBU, RJ45F connector  
 (StudioHub+) ASRC, 44.1kHz to 48kHz sampling rate

Digital Output: Transformer isolated, AES/EBU, 48kHz S/R,  
 RJ45F connector (StudioHub+)

### Power and Environmental

Power Input: 115VAC 50/60Hz (North America Version)  
 230VAC 50/60Hz (Australia, Europe, U.K Versions)

Power Consumption: 15VA

Operating Temp.: 0° to 40° C (32° to 104° F)

Storage Temp.: -20° to 45° C (-4° to 113° F)

Relative Humidity: 0% to 90% non-condensing

Cooling: Venting chassis (fanless)

### Product Dimensions

Product Dimensions: 8.5 x 6.25 x 1.7 inches (21.6 x 16 x 4.32 cm)  
 Product Weight: 3.5 pounds (1.59 kg)

### Shipping Weight & Dimensions

Shipping Dimensions: 12 x 9 x 6 inches (30.5 x 22.9 x 15.3 cm)  
 Shipping Weight: 5 pounds (2.27 kg)

## Compliance in the U.S.

In the U.S., this Gadget complies with the limits for a Class A computer device as specified by FCC Rules, Part 15, Subpart J, which are designed to provide reasonable protection against such interference when this type of equipment is operated in a commercial environment.

### ...and in Canada.

In Canada, this Gadget does not exceed the Class A limits for radio noise emissions set out in the Radio Interference Regulations of the Canadian Department of Communications.

### ...and in Europe.

This Gadget complies with the requirements of the EEC Council Directives 93/68/EEC (CE Marking), 73/23/EEC (safety – low voltage directive), and 89/336/EEC (electromagnetic compatibility). Conformity is declared to standards EN50081-1 and EN50082-1.

### ...and in Wonderland.

This Gadget complies with any and all directives set forth by the Red Queen relating to audio electronic devices, pursuant to the All Ways Are My Ways Act of 1865. No hedgehogs are harmed by the operation of this device.



*Because who would want to harm an innocent hedgehog?*



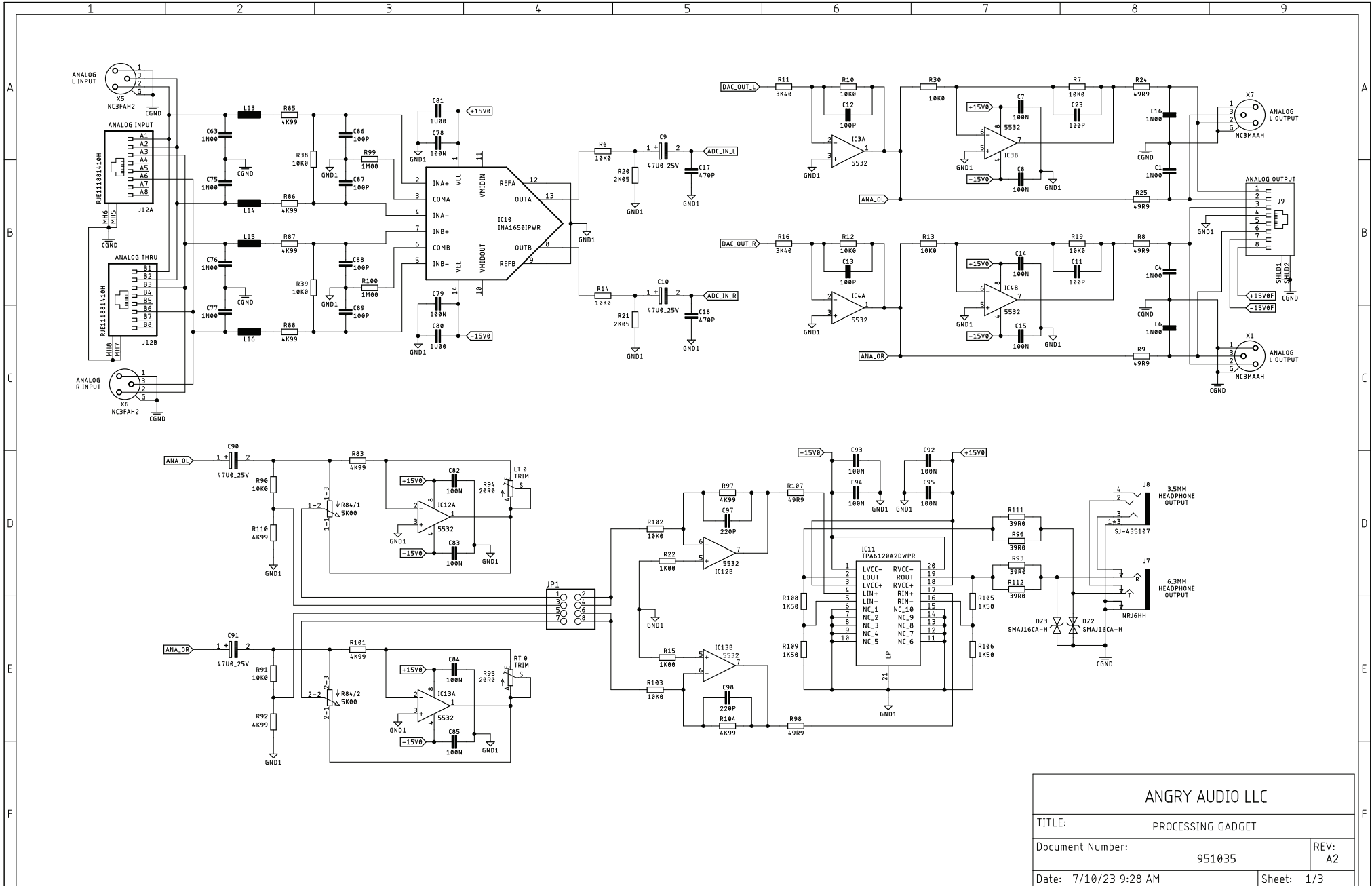

ANGRY AUDIO LLC		
TITLE: PROCESSING GADGET		
Document Number:	951035	REV: A2
Date: 7/10/23 9:28 AM	Sheet: 1/3	

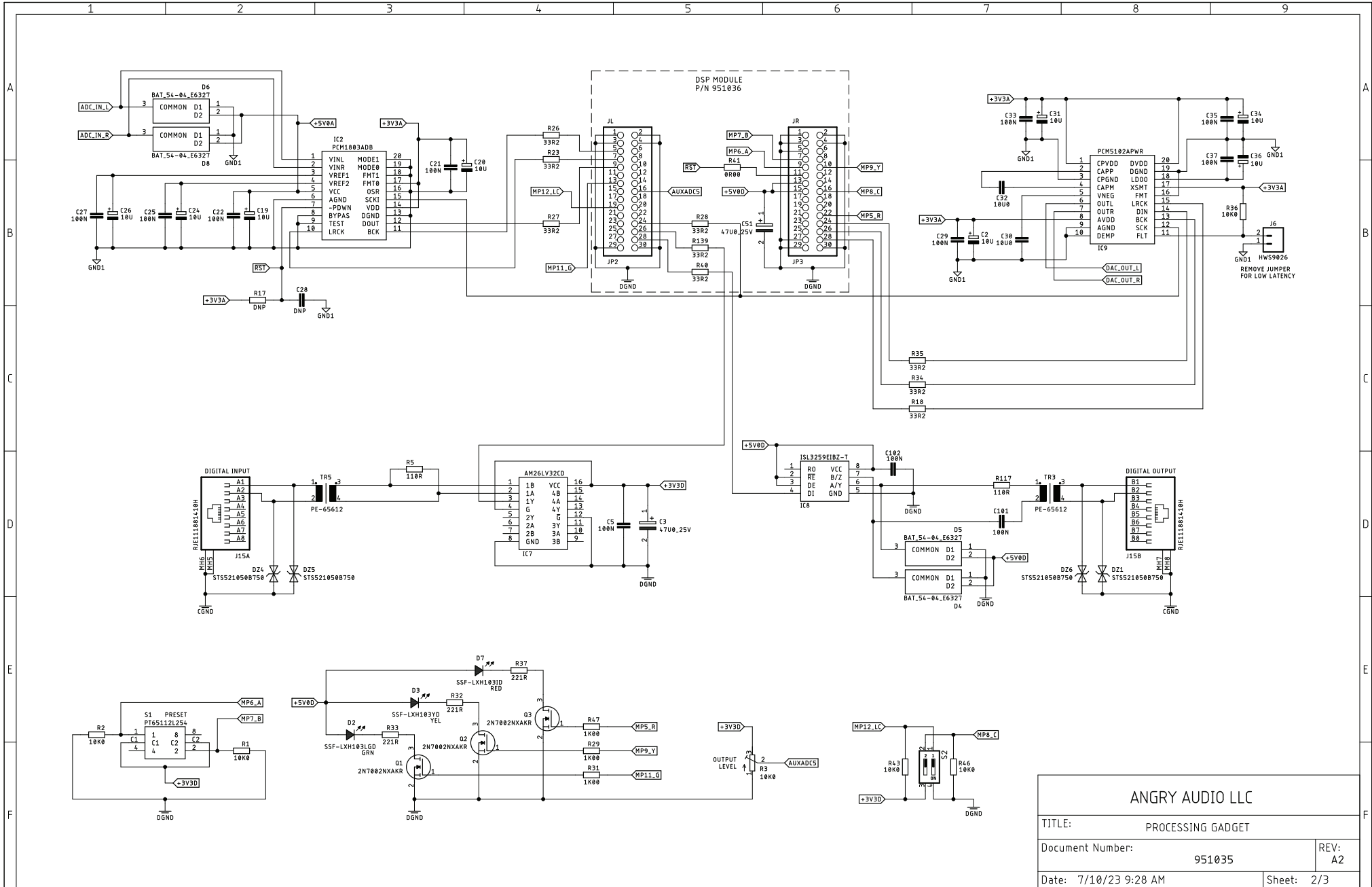

<b>ANGRY AUDIO LLC</b>		
TITLE: PROCESSING GADGET		
Document Number: 951035	REV: A2	
Date: 7/10/23 9:28 AM	Sheet: 2/3	

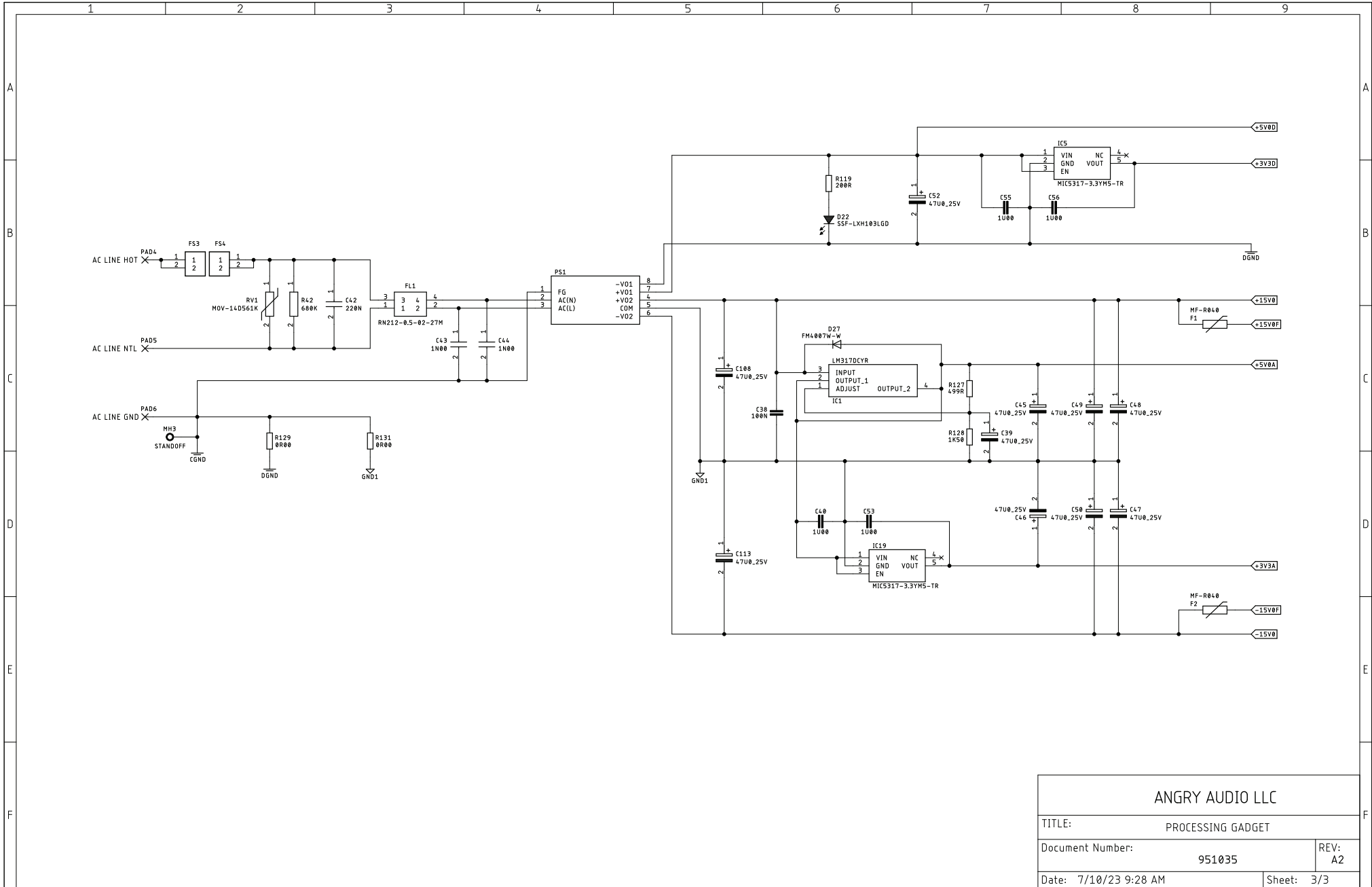

ANGRY AUDIO LLC	
TITLE:	PROCESSING GADGET
Document Number:	951035
Date: 7/10/23 9:28 AM	REV: A2 Sheet: 3/3