

LoLa881

LoLa16161

Professional
Multichannel Sound Cards

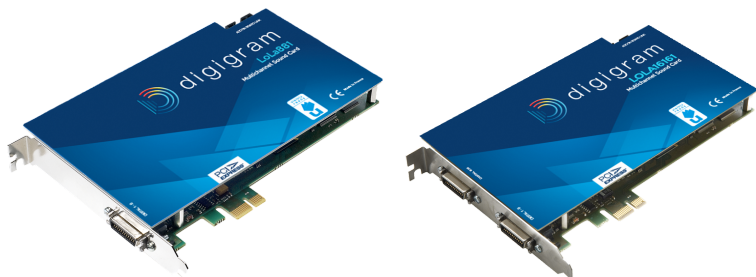

User manual
v10

**For technical support
please contact your system supplier**



Digigram S.A.

82/84 Allée Galilée, 38330 Montbonnot-Saint-Martin, FRANCE
Tel: +33 (0)4 76 52 47 47 • Fax: +33 (0) 4 76 52 18 44 • E-mail: info@digigram.com

Digigram Asia Pte Ltd.

60 Albert Street - #19-11 OG Albert Complex Singapore 189969, Singapore
Tel : +65 6291 2234 • Fax : +65 6291 3433 • E-mail : info_asia@digigram.com

Table of Contents

INFORMATION FOR THE USER	6
IMPORTANT NOTICE	7
CONTENTS OF THIS PACKAGE	8
FEATURES	8
LoLa881 main hardware features	9
LoLa881/SRC main hardware features	9
LoLa16161 main hardware features	9
LoLa16161/SRC main hardware features	9
Main software features	10
MINIMUM REQUIREMENTS	11
HARDWARE INSTALLATION	11
SOFTWARE INSTALLATION	12
Installation under Windows XP, Windows Server 2003, and following versions	12
The ASIO Control panel	14
‘LoLa Manager’ control panel	15
Removing the driver under Windows XP/ Windows Server 2003	16
Removing the driver under Windows following versions	16
How to check the installation	16
SPECIFICATIONS	21
Configuration	21
Inputs	21
Outputs	23
Connectors	23
Audio specifications	23
Development environments	24
APPENDICES	25
LoLa881(/SRC)/LoLa16161(/SRC) schematic diagram	25
LoLa881 layout	26
LoLa16161 layout	26
SCSI connectors for connecting the breakout cables	27
LoLa881/16161, AES 1 – 4 and sync cable connector (before 2016)	28
LoLa881/16161, AES 1 – 4 and sync cable connector (after 2016)	29
Wiring diagram LoLa881/16161, AES 1 – 4 and sync	30
Cable diagram LoLa16161, AES 5 - 8 (before 2016)	31

Cable diagram LoLa16161, AES 5 - 8 (after 2016)	31
Wiring diagram LoLa881/16161, AES 5 - 8	32
Cable diagram LoLa16161 <-> BOB16AES	32
Pinout - LoLa881/16161, AES 1 – 4 and sync	33
Pinout - LoLa16161, AES 5 - 8	34

Copyright 2009 - 2010 Digigram. All rights reserved.

No portion of this manual may be reproduced without prior written consent from Digigram. The copyright protection claimed here includes photocopying, translation and/or reformatting of the information contained in this manual.

While every effort has been made to ensure accuracy, Digigram is not responsible for errors, omissions or typos and reserves the right to make improvements or changes in the products and programs described without notice.

Digigram and the Digigram logo, and LoLa881/16161 are registered trademarks or trademarks of Digigram S.A.. Other trademarks are property of their respective holders.

INFORMATION FOR THE USER

This device complies with part 15 of FCC rules. Operation is subject to the following two conditions: (1) This device may not cause harmful interference, and (2) This device must accept any interference received, including interference that may cause undesired operation.

This equipment has been tested and found to comply with the limits for a CLASS B digital device, pursuant to Part 15 of the FCC Rules. These limits are designed to provide reasonable protection against harmful interference in a residential installation. This equipment generates, uses, and can radiate radio frequency energy and, if not installed and used in accordance with the instructions contained in this data sheet, may cause harmful interference to radio and television communications. However, there is no guarantee that interference will not occur in a particular installation.

If this equipment does cause harmful interference to radio or television reception, which can be determined by turning the equipment off and on, the user is encouraged to try to correct the interference by one or more of the following measures:

- * reorient or relocate the receiving antenna
- * increase the separation between the equipment and the receiver
- * connect the equipment into an outlet on a circuit different from that of the receiver
- * consult the dealer or an experienced audio television technician.

Note: *Connecting this device to peripheral devices that do not comply with CLASS B requirements or using an unshielded peripheral data cable could also result in harmful interference to radio or television reception. The user is cautioned that any changes or modifications not expressly approved by the party responsible for compliance could void the user's authority to operate this equipment. To ensure that the use of this product does not contribute to interference, it is necessary to use shielded I/O cables.*

Warning:

Electrostatic discharge (ESD) can damage several components on the board. To avoid such damage in handling the board, take the following precautions:



Bring the device and everything that contacts it to ground potential by providing a conductive surface and discharge paths. As a minimum, observe these precautions:

- *Disconnect all power and signal sources.*

- *Place the device on a grounded conductive work surface.*
- *Ground yourself via a grounding wrist strap or by holding a grounded object.*
- *Ground any tool that will contact the device.*

IMPORTANT NOTICE

This card has been tested and found to comply with the following standards:

- International: CISPR22 (2005) Class B.
- Europe: EMC 2004/108/CE specifications.
- United States: FCC Rules-Part 15-Class B (digital device).

In order to guarantee compliance with the above standards in an installation, the following must be done:

- the provided cable must not be modified.
- additional cables used must have their respective shield connected to each extremity.

Due to the reduced length of the PCI EXPRESS™ bus connector and the resulting lack of mechanical stability, we strongly advise against transporting the card(s) installed in a computer, unless its chassis or case provides a dedicated support to keep the card securely in place in order to avoid physical damage.

CONTENTS OF THIS PACKAGE

You have just acquired a LoLa sound card by Digigram and we congratulate you!

The package consists of the following components:

- One of the following sound card: LoLa881, LoLa881/SRC, LoLa16161, LoLa16161/SRC ("/SRC" refers to boards including the *Sample Rate Converter* option for the inputs)

The end user version additionally includes:

- A primary cable
- a secondary cable (LoLa16161 and LoLa16161/SRC only)

For the OEM version, the cables are available optionally.

FEATURES

LoLa881 and LoLa16161 are audio cards for PCI EXPRESS™ x1 (PCIe®) bus. They are compatible with PCIe® slot x1, x4, x8, x16.

LoLa881 main hardware features

- 4 AES/EBU stereo inputs^{1*} (from 20KHz to 192 kHz)
- 4 AES/EBU* stereo outputs (from 20KHz to 192 kHz)
- 1 AES/EBU* sync input (up to 192 kHz in play and record)
- 1 standard Word Clock input (up to 192 kHz)
- 1 standard Word Clock output (up to 192 kHz)
- 1 PAL/NTSC video sync input

LoLa881/SRC main hardware features

- 4 AES/EBU stereo inputs* with h/w Sample Rate Converter (from 20KHz to 216KHz)
- 4 AES/EBU* stereo outputs (from 20KHz to 192 kHz)
- 1 AES/EBU* sync input (up to 192 kHz in play and record)
- 1 standard Word Clock input (up to 192 kHz)
- 1 standard Word Clock output (up to 192 kHz)
- 1 PAL/NTSC video sync input

LoLa16161 main hardware features

- 8 AES/EBU stereo inputs* (from 20KHz to 192 kHz)
- 8 AES/EBU stereo outputs (from 20KHz to 192 kHz)
- 1 AES/EBU sync input* (up to 192 kHz in play and record)
- 1 standard Word Clock input (up to 192 kHz)
- 1 standard Word Clock output (up to 192 kHz)
- 1 PAL/NTSC video sync input

LoLa16161/SRC main hardware features

- 8 AES/EBU stereo inputs* with h/w Sample Rate Converter (from 20KHz to 216KHz)
- 8 AES/EBU stereo outputs (from 20KHz to 192 kHz)
- 1 AES/EBU sync input* (up to 192 kHz in play and record)
- 1 standard Word Clock input (up to 192 kHz)
- 1 standard Word Clock output (up to 192 kHz)
- 1 PAL/NTSC video sync input

^{1*} supporting 32-bit ASIO applications

Main software features

- Real-time, simultaneous record and playback in PCM (8, 16 and 24 bits and 32 bits Float)
- LoLa Manager application by Digigram allowing to easily configure and control the boards.
- Low latency DirectSound and ASIO^{2*} drivers

^{2*} can be used as S/PDIF interfaces as well

MINIMUM REQUIREMENTS

Minimum hardware requirements

PC with one free PCI EXPRESS™ (PCIe®) slot (x1, x4, x8 or x16).

The power of the processor and the memory depend on application and operating system used on the PC.

Software requirements

The LoLa881(/SRC) or LOLA16161(/SRC) requires installation of the drivers included in the LoLa Kit version 1.03 or higher.

The LoLa Kit includes:

- a WDM DirectSound driver
- an ASIO driver^{3*}
- LoLa Manager application to configure and control the boards

OS supported

LoLa881 and LoLa16161 run under Windows XP, Windows Server 2003, Windows Server 2008, Windows Vista, and Windows 7.

HARDWARE INSTALLATION

Due to the reduced length of the PCI EXPRESS™ bus connector and the resulting lack of mechanical stability, we strongly advise against transporting the card(s) installed in a computer, unless its chassis or case provides a dedicated support to keep the card securely in place in order to avoid physical damage.

The card has to be installed in the computer prior to installing its driver.

Installing the card

Gently plug the card in a free PCIe® slot and press it down to position it firmly. Tighten the fastening screw of the bracket, or lock the card by means of the mechanism provided for this purpose on your computer.

SOFTWARE INSTALLATION

Note: *the installation of the software requires administrator rights on your computer*

Please visit the Digigram web site for the most recent [driver](#) or [firmware](#) (LoLa881/[LoLa16161](#)).

In case you run a specific application developed or installed by a Digigram Partner, it might require the use of a specific driver or firmware version. In this case, make sure that the updated driver has been approved by your supplier.

Installation under Windows XP, Windows Server 2003, and following versions

If the driver has been downloaded from our web site, it has to be expanded prior to the driver's installation as follows: Double-click on the downloaded file (self-expanding). You can use the default destination location (Windows temporary folder) or select another directory.

- Shutdown your computer and insert the card.
- Restart your computer.
- Click **Cancel** if the “**Found New Hardware**” wizard appears.
- Double-click onto the Digigram **LoLa Kit vxx.msi** to launch the driver installation.
- A welcome message is displayed, click **Next** to continue.
- The “**License Agreement**” window appears: read it, and click on “**I accept the terms in the license agreement**” to approve it.
- The WDM DirectSound and ASIO drivers are now installed.
Next.
- In the “**Ready to Install the Program Window**”, click on **Install** to start copying the files.
 - **Note:** *In case you use an unsigned driver version, the “Digital Signature Not Found” message may appear because a non-Microsoft software is about to be installed. Click **Continue** in the “Hardware installation” window (Windows XP, Server 2003).*

- ***Under Windows Vista, Server 2008, and following versions:***
*Click **Allow** in the “User Account Control” window.*
*Click **Install** in the “Windows Security” window.*
- Click **Continue** in the “**Hardware installation**” window.
- Click on the **Finish** button to complete the driver installation.

The ASIO Control panel

Note: for most current ASIO applications (e.g. Cubase, Nuendo, etc...) you have the choice between a 32-bit version and a 64-bit version when installing them under Windows \geq Vista. For operation with your LoLa sound card, make sure to use the 32-bit version!

To launch this interface, go to <Start>, <Programs>, <LoLa>, <LoLa ASIO Settings>. For help on how to use this control panel, please refer to its on-line help (“? Help” button).

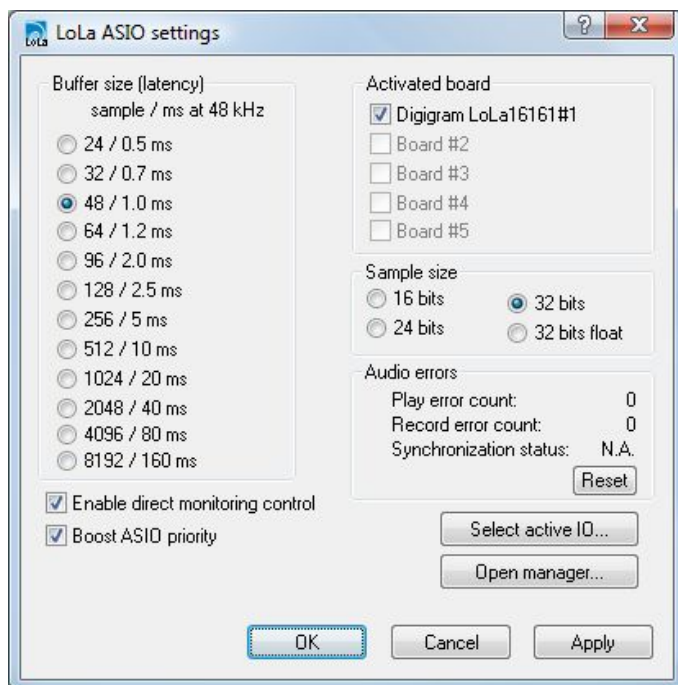

‘LoLa Manager’ control panel

To launch this interface, go to **<Start>**, **<Programs>**, **<LoLa>**, **<LoLa Manager>**.

It allows to:

- access the latency settings of the card(s)
- select the synchronization clock source
- select a LoLa board in case more than one has been installed in the computer
- enable/disable the sampling frequency converters
- synchronize several boards
- display the synchronization status

For help on how to use this control panel, please refer to its on-line help.

Removing the driver under Windows XP/ Windows Server 2003

- Open the **Windows Control Panel** and double-click on the **Add/Remove Software** icon.
- Select “**Digigram LoLa Kit...**”, and **Change/Remove**.
- Select **Remove** in the “**LoLa Kit**” window.
- Follow the instructions to complete the driver removal.

Removing the driver under Windows following versions

- Open the **Windows Control Panel** and double-click on the **Programs and Features** icon.
- **Select Digigram LoLa Kit... vxx.msi and Remove.**
- Follow the instructions to complete driver removal.

How to check the installation

Once the driver and the cards are installed according to the procedure described in this manual, you can verify that the card is properly installed and works fine as follows:

- Menu **<Start>**, **<Settings>**, **<Control panel>**, **<Sound and Multimedia>**, tab “**Audio**”, **Default device** (Playback device, Recording device). The card’s channels can be selected.

WDM DirectSound playback devices available under Windows XP:

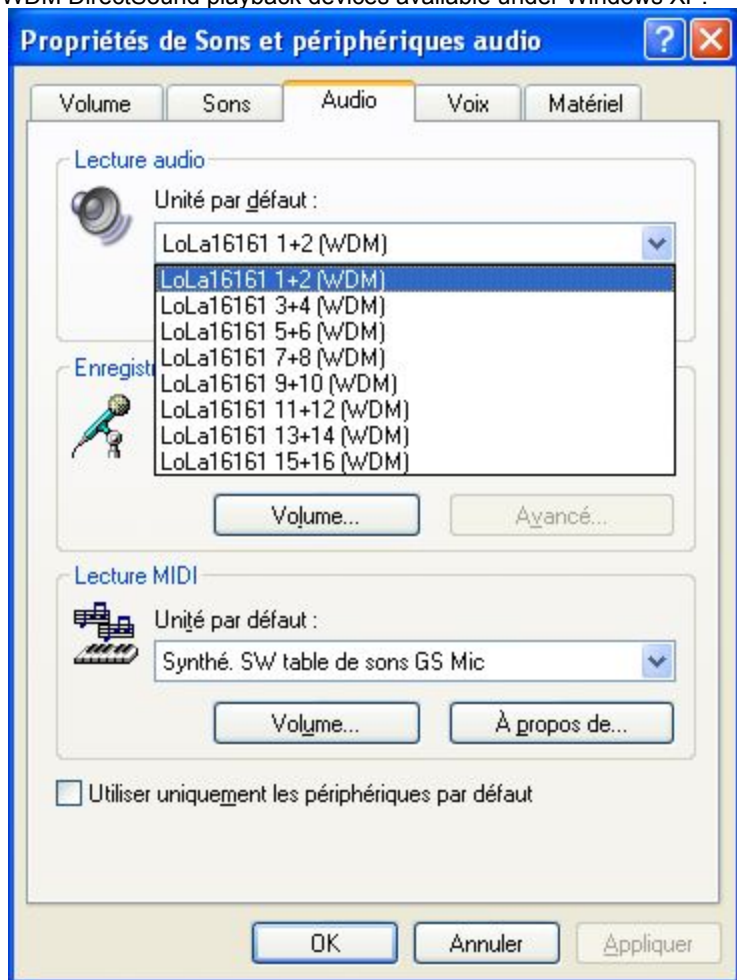

The DirectSound “**Playback**” devices correspond to the physical outputs of the card.

WDM DirectSound recording devices available under Windows XP:

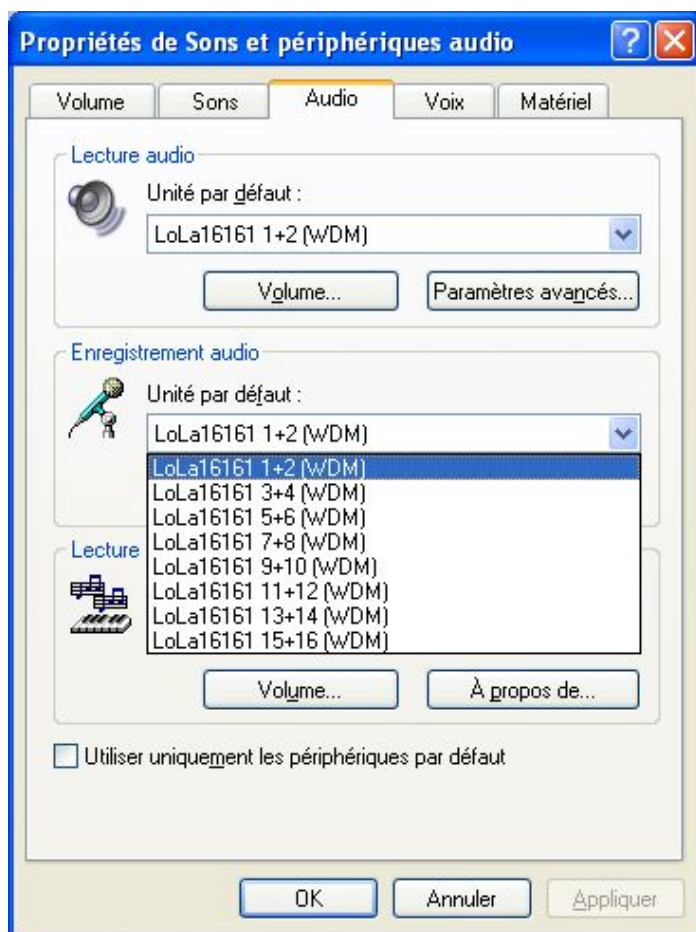

The DirectSound "Record" devices correspond to the physical inputs of the card.

WDM DirectSound playback devices available under Windows Vista, Server 2008, and following versions:

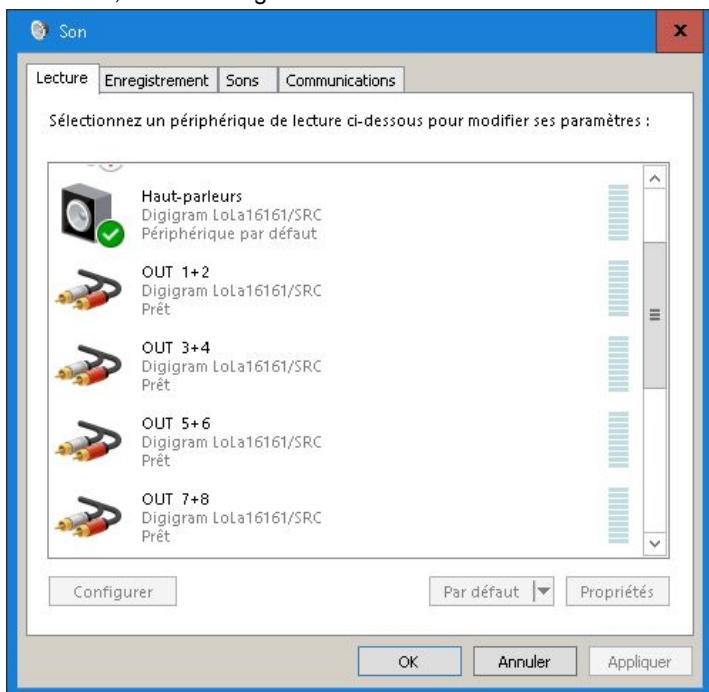

The DirectSound Playback device OUT x+y correspond to the physical outputs number x & y of the card.

The DirectSound Playback device "Speaker" of the LoLa16161 or LoLa881 corresponds to the 8 channels (1 to 8). This Speaker device can be configure manually as stereo or multi-channel, from its properties.

Pay attention to the fact that the use of the Speaker device prevents from using the other stereo devices.

WDM DirectSound recording devices available under Windows Vista, Server 2008, and Windows 7:

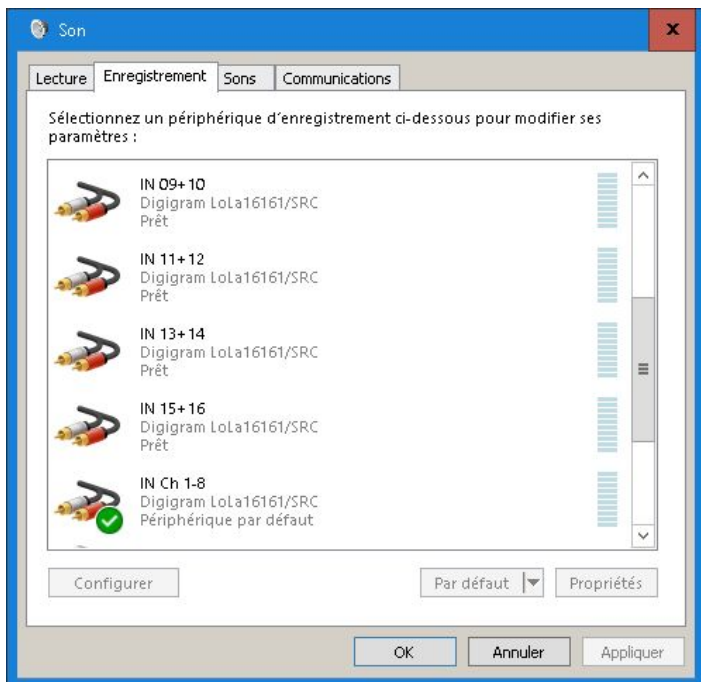

The DirectSound Recording device “IN x+y” corresponds to the physical inputs of the card x & y.

The recording device IN Ch1-8 uses channels 1 to 8. When this device is used, the other stereo devices can't be used.

- The card can be used with any DirectSound application.
- Launch the LoLa Mixer from **<Start> <Programs> <LoLa> <LoLa Manager>** to see the cards in the “**Board:**” combo-box and to select them.
- The card is visible from any (32-bit) ASIO application.

SPECIFICATIONS

Configuration

	LoLa881(/SRC)	LoLa16161(/SRC)
Bus/Format	PCI EXPRESS™ (PCIe®) slot (x1, x4, x8, x16).	
Size	168 mm x 111 mm x 20 mm	
Power requirements (+3.3 V / +12 V)	0,6A / 0,01A with SRC 0,8A / 0,01A w/o SRC	0,7A / 0,01A with SRC 1,1A / 0,01A w/o SRC
Operating: temp / humidity (non-condensing)	0°C / +50°C • 5% / 90%	
Storage: temp / humidity (non-condensing)	-5°C / +70°C • 0% / 95%	

Inputs

	LoLa881(/SRC)	LoLa16161(/SRC)
Digital inputs (stereo)	4 AES/EBU* 20KHz to 192 kHz	8 AES/EBU* 20KHz to 192 kHz
Digital inputs (stereo) with SRC (/SRC boards)	4 AES/EBU* with h/w sample rate converters, 16:1 à 1:16, 20KHz to 192 kHz Dynamic: 144dB THD+N: -140dB	8 AES/EBU* with h/w sample rate converters, 16:1 à 1:16, 20KHz to 192 kHz Dynamic: 144dB THD+N: -140dB

LoLa881 & LoLa16161

User manual

Other inputs	<ul style="list-style-type: none">• AES/EBU Sync* (from 20KHz to 192 kHz managed by driver, h/w 216 kHz)• Word clock (up to 192 kHz)• video sync (PAL, NTSC, 32000 Hz – 192000 Hz)
AES11 synchronization	Yes

Outputs

	LoLa881(/SR C)	LoLa16161(/S RC)
Digital outputs (stereo)	4 AES/EBU, 20KHz to 192 kHz (up to 192 kHz managed by driver, h/w 216 kHz)	8 AES/EBU, 20KHz to 192 kHz
Other outputs	Word Clock (up to 192 kHz)	

Connectors

	LoLa881(/SR C)	LoLa16161(/S RC)
Internal connector	Add-on board link (<i>reserved for future use</i>)	
External connector(s)	1 x 26-pin SCSI MDR	2 x 26-pin SCSI MDR

Audio specifications

	LoLa881(/SR C)	LoLa16161(/S RC)
Sampling frequency	Programmable from 32 to 192 kHz	
Hardware mixer	Special development required – contact Digigram	
Supported audio formats	PCM (16, 24, 32 bits, Float IEEE754)	

LoLa881 & LoLa16161

User manual

Development environments

	LoLa881(/SRC)	LoLa16161(/SRC)
Other management	ASIO (32-bit), DirectSound	
OS supported	Windows XP, Windows Server 2003, and Windows following versions	
Main on-board processing features	PCM, play+record	

APPENDICES

LoLa881(/SRC)/LoLa16161(/SRC) schematic diagram

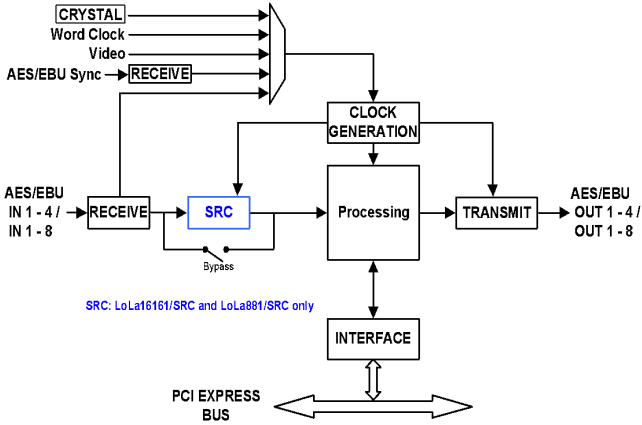

LoLa881 layout

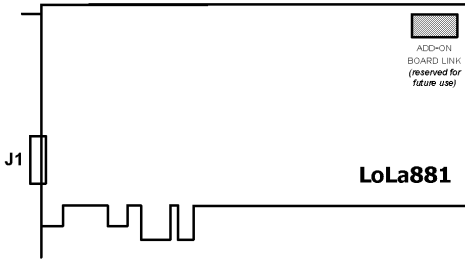

J1: AES 1 – 4 and sync cable connector

LoLa16161 layout

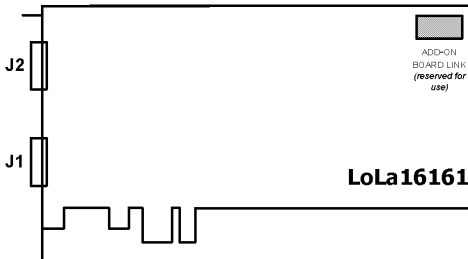

J1: AES 1 – 4 and sync cable
J2: AES 5 - 8 cable connector

SCSI connectors for connecting the breakout cables

SCSI connectors before 2016



The I/O cable connector is maintained through the clips.

SCSI connectors since 2016



The cable is now tied to the card thanks to the locking screws.

LoLa881/16161, AES 1 – 4 and sync cable connector (before 2016)

Schematic diagram of the cable delivered by Digigram*:

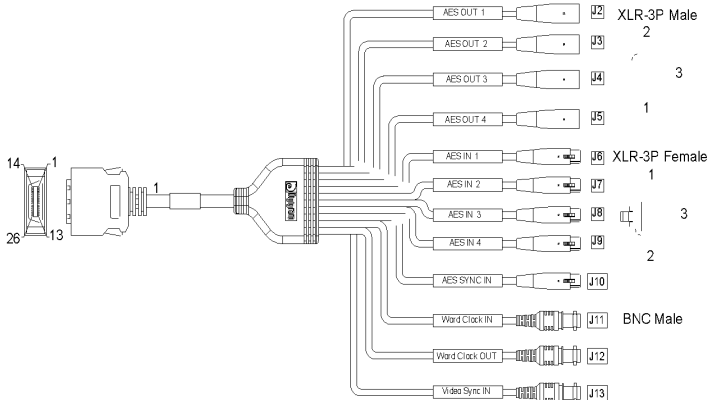

* Your cable may look different if it is not a Digigram cable.

LoLa881/16161, AES 1 – 4 and sync cable connector (after 2016)

Schematic diagram of the cable delivered by Digigram*:

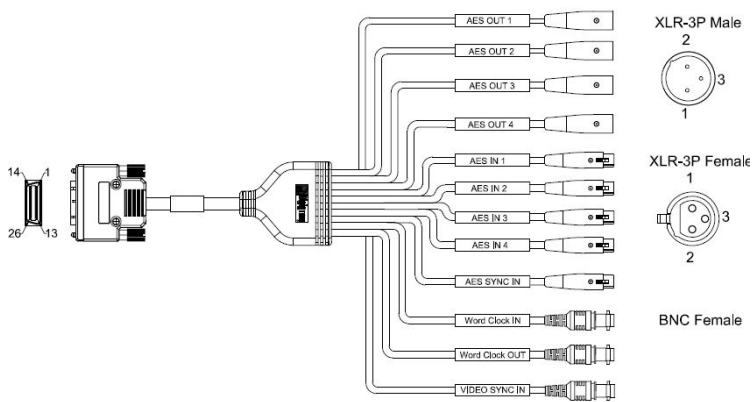

Your cable may look different if it is not a Digigram cable.

Wiring diagram LoLa881/16161, AES I – 4 and sync

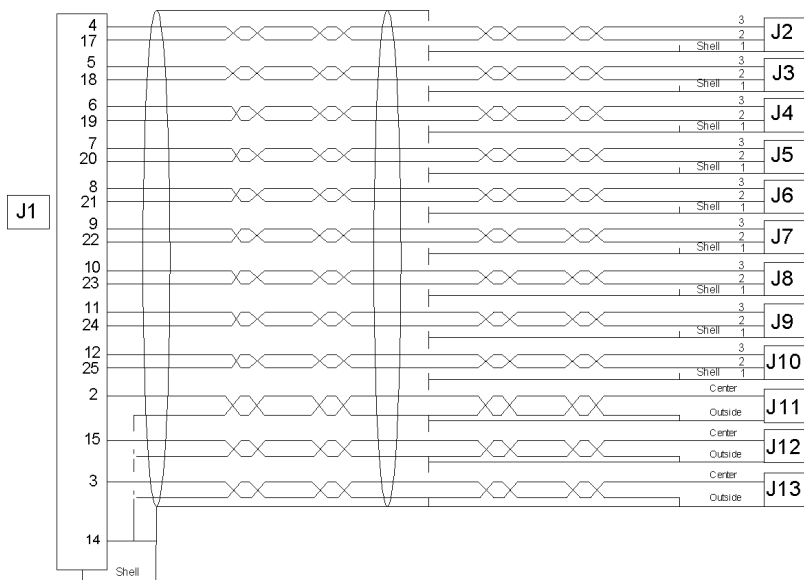

Cable diagram LoLa16161, AES 5 - 8 (before 2016)

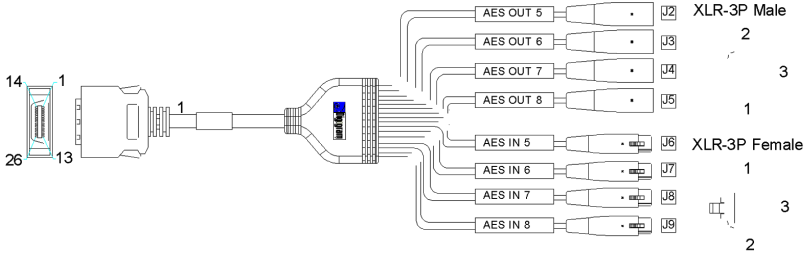

Schematic diagram of the cable delivered by Digigram*:

* Your cable may look different if it is not a Digigram cable.

Cable diagram LoLa16161, AES 5 - 8 (after 2016)

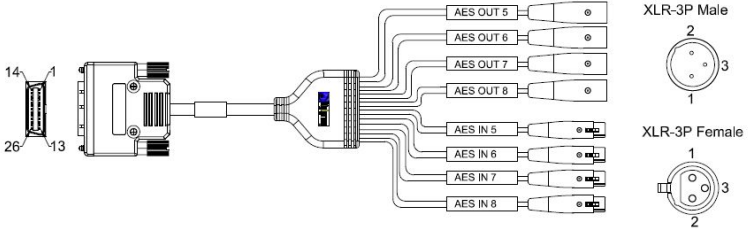

Schematic diagram of the cable delivered by Digigram*:

* Your cable may look different if it is not a Digigram cable.

Wiring diagram LoLa881/16161, AES 5 - 8

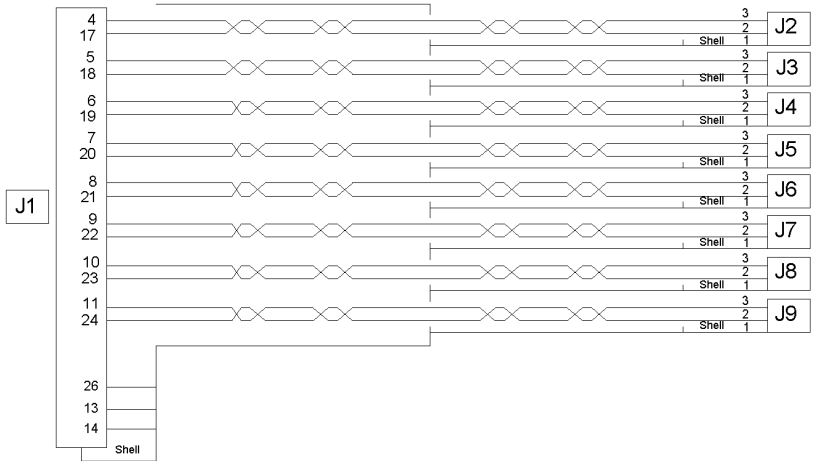

Cable diagram LoLa16161 <-> BOBI6AES

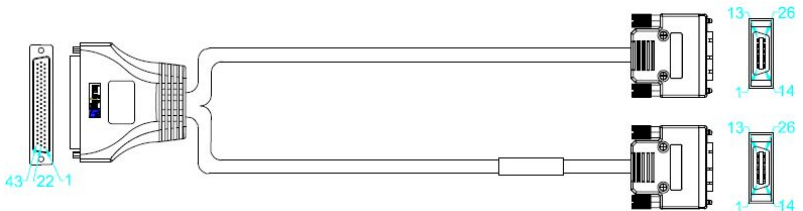

Schematic diagram of the cable delivered by Digigram*:

* Your cable may look different if it is not a Digigram cable.

Pinout - LoLa88I/1616I, AES I – 4 and sync

Pin	Signal	Pin	Signal
1	reserved	14	GND
2	Word Clock IN	15	Word Clock OUT
3	Video IN	16	reserved
4	AES/EBU OUT 1 +	17	AES/EBU OUT 1 -
5	AES/EBU OUT 2 +	18	AES/EBU OUT 2 -
6	AES/EBU OUT 3 +	19	AES/EBU OUT 3 -
7	AES/EBU OUT 4 +	20	AES/EBU OUT 4 -
8	AES/EBU IN 1 +	21	AES/EBU IN 1 -
9	AES/EBU IN 2 +	22	AES/EBU IN 2 -
10	AES/EBU IN 3 +	23	AES/EBU IN 3 -
11	AES/EBU IN 4 +	24	AES/EBU IN 4 -
12	AES/EBU SYNC +	25	AES/EBU SYNC -
13	Reserved	26	reserved

Pinout - LoLa16161, AES 5 - 8

Pin	Signal	Pin	Signal
1	reserved	14	GND
2	reserved	15	reserved
3	reserved	16	reserved
4	AES/EBU OUT 5 +	17	AES/EBU OUT 5 -
5	AES/EBU OUT 6 +	18	AES/EBU OUT 6 -
6	AES/EBU OUT 7 +	19	AES/EBU OUT 7 -
7	AES/EBU OUT 8 +	20	AES/EBU OUT 8 -
8	AES/EBU IN 5 +	21	AES/EBU IN 5 -
9	AES/EBU IN 6 +	22	AES/EBU IN 6 -
10	AES/EBU IN 7 +	23	AES/EBU IN 7 -
11	AES/EBU IN 8 +	24	AES/EBU IN 8 -
12	reserved	25	reserved
13	GND	26	GND