

SONIFEX

Redbox RB-SSML1

Mic/Line Source Selector with Compressor/Limiter

2014-15
Catalogue





RB-SSML1 Mic/Line Source Selector with Compressor/Limiter



Category: Mixers, Source Selectors & Switchers.

Product Function: Compressing or limiting an incoming mic or stereo line signal, mixing with a stereo monitor input for metering and mixing to two headphone outputs.

Typical Applications: Designed for voice-over & over-dubbing applications in voice-over booths/suites, use with audio codecs.

Features:

- Two headphone outputs.
- Mic high pass filter & phantom power.
- Wide mic gain range adjustment.
- Line inputs & outputs can be balanced or wired unbalanced.
- Compression ratio & threshold limits adjustment.
- Bright LED output level metering.

The RB-SSML1 is a 1U rack-mountable source selector for compressing or limiting an incoming microphone or stereo line signal and mixing this signal with a stereo monitor input, which can then be metered and mixed to two headphone outputs. The unit is mainly used in situations where level control is required, for example in voiceover applications.

The mic input consists of an independent low-noise microphone pre-amplifier for converting microphone level signals to a line level. There are independent switches to control a high pass filter (low frequency roll-off at 125Hz) and to provide phantom power at +48V to the connected microphone. A preset pot on the rear panel allows adjustment of the mic gain from 36dB to 75dB.

A front panel switch selects between mic & line inputs. Both mic and line inputs have fully adjustable volume control via front panel pots, with an additional 10dB gain increase for the line input via a rear panel switch, for use with unbalanced equipment. The mono mic input is converted to a stereo signal before being passed to the compressor/limiter.

The XLR-3 stereo monitor input has an adjustable volume control via a back panel recessed pot, and has an additional 10dB gain increase via a switch on the rear panel, for use with unbalanced equipment. The audio on this input is only present on the headphone outputs, and is therefore suitable as a return feed from a codec, a PC audio output, or similar equipment.

The compression ratio and threshold limits of the compressor/limiter section are fully adjustable via linear pots situated on the front panel. The threshold can be set between -30dBu and +20dBu. When the input signal rises above the threshold level a soft-knee compression is applied at the selected ratio. The compressor has an attack time of approximately 20ms and a release time of approx 400ms, and can operate at ratios of 1:1 (no compression) to :1 (limiting). A front panel BYPASS button can be used, where no compression is applied. A rear-panel DIPswitch allows compression only to be applied to the mic input and not the stereo line input.

The metering is carried out after the compressor/limiter section and consists of two rows of 12 round LEDs showing levels

between -17dB and +11dB. An internal jumper allows the metering to follow either the stereo output, or the headphone monitor outputs and a rear panel DIPswitch can disable the peak hold display.

The XLR-3 stereo line output can be fed from either the mic or line input, but not the stereo monitor input. The line output is electronically balanced and can be wired unbalanced by grounding the non-phase signal, allowing you to feed both balanced and unbalanced equipment. A pushbutton switch is provided to reduce the output by 10dB for this purpose.

An LED power indicator on the front panel displays the power supply connection.

Specification For RB-SSML1

Technical Specification		
Maximum Input Level:	-10dBu (mic), +28dBu (line), electronically balanced	
Input Impedance:	20kΩ nominal balanced	
Maximum Output Level:	+28dBu	
Output Impedance:	<50Ω	
Low Frequency	125Hz @ 6dB/octave	Roll-Off:
Gain Range (mic):	Adjustable 36dB to 75dB gain (-80dB volume min.)	
Volume Control (line):	-80dB to +6dB gain (-70dB +16dB with additional input gain)	
E.I.N.:	130dB	
Distortion:	<0.02% THD @ 1kHz, ref +8dBu output	
Common Mode Rejection:	>66dB typically	
Phantom Power:	48V	
Frequency Response:	20Hz to 20kHz ±0.3dB (600Ω load, ref 1kHz)	

Connections	
Mic Input:	1 x XLR 3 pin female (Balanced)
Line Input:	2 x XLR 3 pin female (Balanced)
Monitor Input:	2 x XLR 3 pin female (Balanced)
Output:	2 x XLR 3 pin male (Balanced, can be unbalanced)
Headphone Outputs:	2 x ¼" (6.35mm) A-gauge 3-pole stereo jack sockets
Mains Input:	Filtered IEC, 110V-120V, or 220-240V switchable, fused, 9W maximum
Fuse Rating:	Anti-surge fuse 100mA 20 x 5mm (230VAC) Anti-surge fuse 250mA 20 x 5mm (115VAC)

Equipment Type	
RB-SSML1:	Mic/Line source selector with compressor/limiter

Physical Specification	
Dimensions (Raw):	48cm (W) x 10.8cm (D) x 4.2cm (H) (1U) 19" (W) x 4.3" (D) x 1.7" (H) (1U)
Dimensions (Boxed):	58.5cm (W) x 22.5cm (D) x 7cm (H) 23" (W) x 8.9" (D) x 2.8" (H)
Weight:	Nett: 1.3kg Gross: 2.0kg Nett: 2.9lbs Gross: 4.4lbs

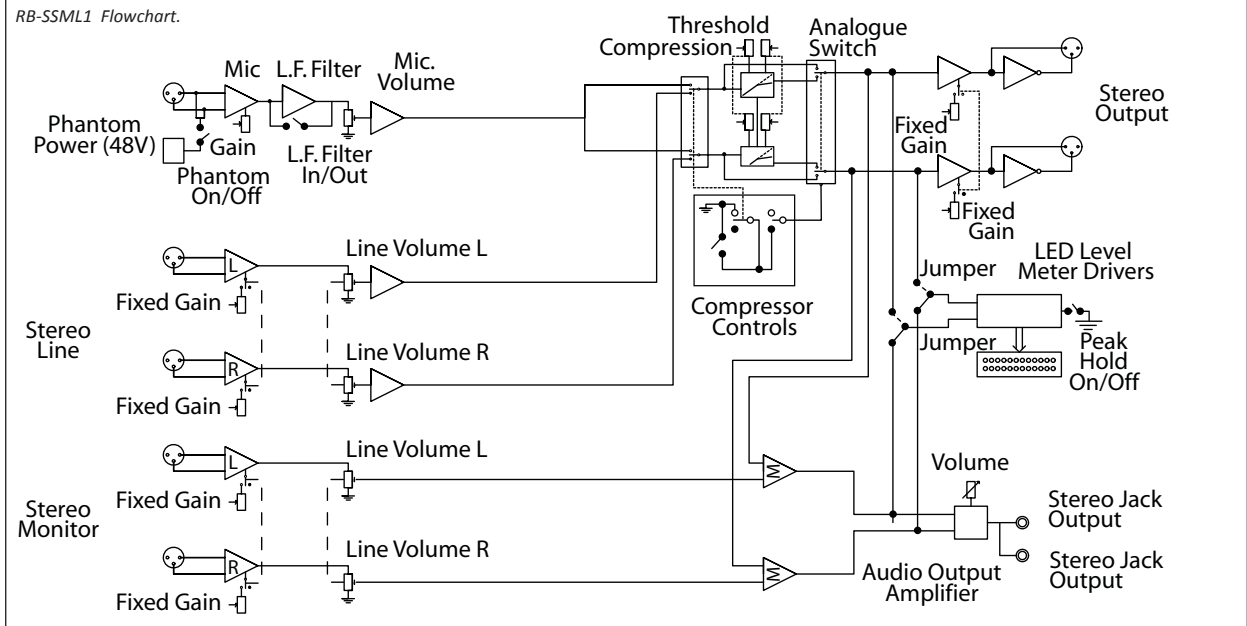

SONIFEX

www.sonifex.co.uk

UK Office:

Sonifex Ltd

61 Station Road, Irthlingborough,

Northants, NN9 5QE, UK

Tel: +44 (0) 1933 650700

Fax: +44 (0) 1933 650726

Email: sales@sonifex.co.uk

Australian Office:

Sonifex Pty Ltd

Unit 12/6 Leighton Place, Hornsby,

New South Wales 2077, Australia

Tel: +61 (2) 9987 0499

Fax: +61 (2) 9476 4950

Email: sales@innescorp.com.au