

- Variable pattern ○∞∞
- Rectangular large dual membrane capsule
- Built in pop protection
- - 12 dB pre-attenuation
- Shock absorbing rubber fitted capsule

Frequency response (see graph)	20 - 20 000 Hz
Polar pattern	Cardioid, omni and figure-of-eight
Pre-attenuation (switchable)	-12 dB
Max. SPL (1 % THD at 1 kHz)	132/144 dB
Sensitivity at 1kHz	21,5 mV / Pa ± 1 dB
A-weighted noise level (IEC 179-A)	12 dB
Power supply	48 V ± 4 V phantom
Current consumption	4,2 mA
Output impedance	< 200 Ω
Minimum load impedance	1 kΩ
Connection	3-pin XLR pin 1: earth (Shield) pin 2: plus (Hot) pin 3: minus (Cold)
Net weight	230 g
Length	145 mm
Diameter	27 mm



Frequency response (at 1m distance)

The frequency response may vary within ± 2,5 dB of the published graph.
Before delivery, each microphone is measured and accompanied with it's own graph.

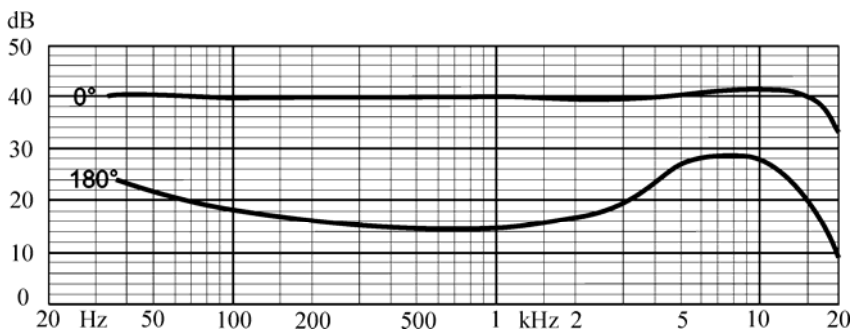

Polar diagram

Cardioid

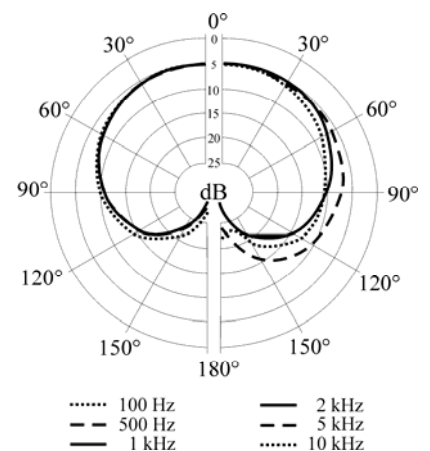

Milab Microphones AB

Mailing address
P. O. Box 1342
S-251 13 HELSINGBORG
SWEDEN

Office address
Norra Strandgatan 4

Phone
+46 42 381620

Fax
+46 42 136350

E-mail
milab@milabmic.com

Internet
www.milabmic.com

DC-196 Condenser Microphone

Art.No 1133

Frequency response and polar diagram on the DC-196 Microphone for different settings.

Cardioid

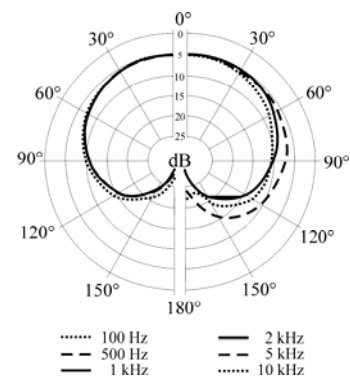
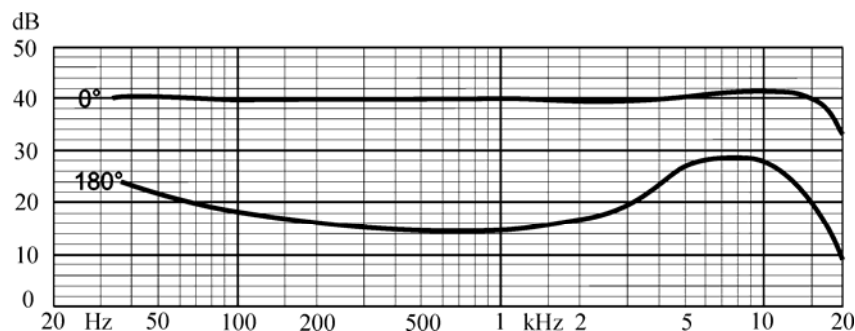

Omni

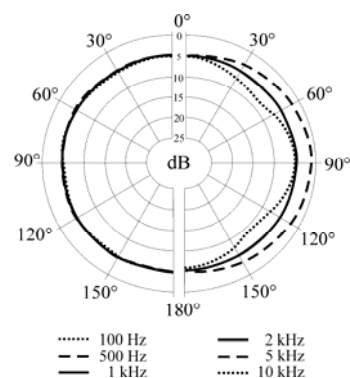
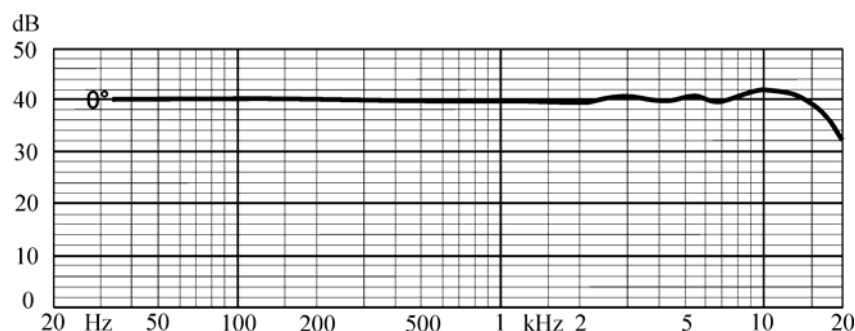

Eight

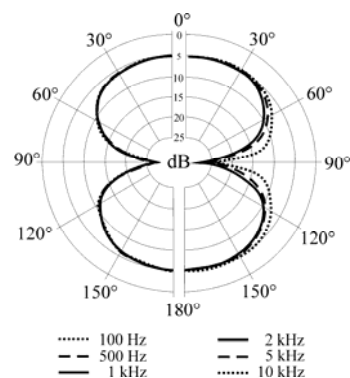
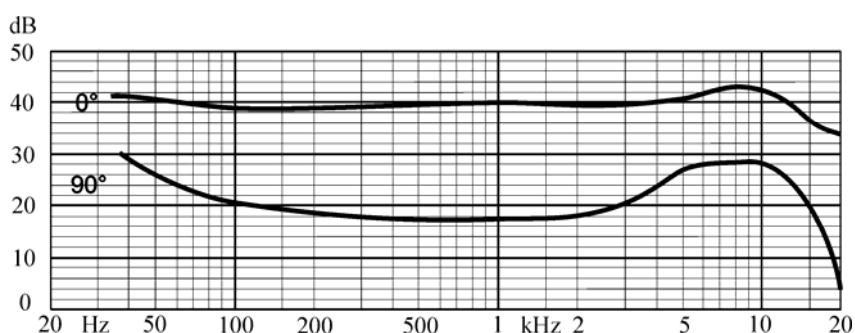

Milab Microphones AB

Mailing address
P. O. Box 1342
S-251 13 HELSINGBORG
SWEDEN

Office address
Norra Strandgatan 4

Phone
+46 42 381620

Fax
+46 42 136350

E-mail
milab@milabmic.com

Internet
www.milabmic.com